

THINKING ELECTRONIC INDUSTRIAL CO., LTD.

HEAD OFFICE: 8F-1, No.93, Ta-Shun 1st Rd., Kaohsiung, Taiwan
 TEL: 886-7-5577660 FAX: 886-7-5570560

MANUFACTURING SITE

- KAOHSIUNG FACTORY: No.51, Kaifa Road, Nantze Export Processing Zone, Kaohsiung City 81170, Taiwan
 TEL: 886-7-9616668 FAX: 886-7-9616698
- CHANGZHOU FACTORY: No.82, Renmin Mid Rd., WuJin High&New-Tech Industrial Development Zone, ChangZhou, JiangSu, China
 TEL: 86-519-86578999 FAX: 86-519-86558643
- DONG GUAN FACTORY: Chiao-Tou Tsun, Sha-Tao Hsiang, Chang-An Town, Dong-Guan City 523863, Guangdong, China
 TEL: 86-769-85542016 FAX: 86-769-85546890
- YICHANG FACTORY: No. 283 Xiaoting Avenue, Xiaoting Dist., Yichang City 443007, Hubei, China
 TEL: 86-717-6510010 FAX: 86-717-6511430



SPECIFICATION FOR APPROVAL

CUSTOMER	Codico
CERTIFIED MODEL/TYPE	SCK-802X
PART NO.	SCK15802XLFY501(RoHS+HF)
APPLICATION	
CUSTOMER P/N	
ISSUE DATE	Mar.14,2016
REV. NO	
REV. DATE	

FOR CUSTOMER APPROVAL	CHECKED BY
	<i>Jing Feng</i>
	APPROVED BY
	<i>Huaifang Zhang</i>





REVISED RECORD SHEET

REV. NO	REV. DATE	REVISED CONTENT



INDEX	Page
■ Part Number Code	1
■ Structure and Dimensions	2
■ Electrical Characteristics	2
■ Reliability	3
■ Soldering Recommendation	4
■ Max. Current Derating Curve	5
■ RoHS Compliant Declaration	5
■ Warehouse Storage Conditions of Products	5
■ Taping and Dimensions	6
■ Standard Packing	7
■ Safety Approvals & Certificates & Test Report	8
■ R-T Characteristic Curve	9
■ V-I Characteristic Curve	10



Part Number Code

Example :

SCK **15** **80** **2X** **L** **F** **Y501**
 (1) (2) (3) (4) (5) (6) (7)

No.	Item	Digit	Specification
(1)	Product Type	SCK	Thinking NTC thermistor SCK type
(2)	Body Size	15	φ 15 mm
(3)	Zero Power Resistance at 25°C (R ₂₅)	80	Refer to " Electrical Characteristics"
(4)	Max. Steady State Current at 25°C	2X	Refer to " Electrical Characteristics"
(5)	Tolerance of R ₂₅	L	± 15%
(6)	Appearance	F	Y kink Lead
(7)	Optional Suffix	Y501	RoHS+HF compliance Repositioning tapping Taping12.7mm&Reel R ₂₅ :60Ω I _{max} :2A

Structure and Dimensions

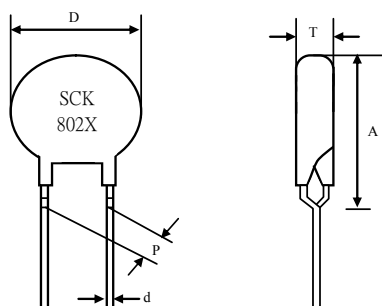

(unit : mm)

Body Size	D max.	P	d	A max.	T max.
φ 15mm	16	7.5±0.5	0.8±0.02	19	7

Electrical Characteristics

Part No.	Zero Power Resistance at 25°C	Tolerance of R ₂₅	Max.Current at 25°C	Residual Resistance at 25°C I _{max}	Max. Power Rating at 25°C
	R ₂₅ (Ω)	(± %)	I _{max} (A)	R _{I_{max}} (Ω)	P _{max} (W)
SCK15802XLFY501	60	15	2	0.693	3.6

Part No.	Dissipation Factor	Thermal Time Constant	Capacitance at 240Vac	Operating Temperature Range
	δ (mW/°C)	τ (sec.)	(μF)	T _L ~T _U (°C)
SCK15802XLFY501	Approx. 21	Approx. 75	560	-40 ~+200

Note:Due to the mechanical force, which is acted on the wire lead, the coating may have cracks and chips. However, it does not affect the performance and reliability of the component.

Reliability

Item	Standard	Test conditions / Methods	Specifications															
Tensile Strength of Terminals	IEC60068-2-21	Gradually applying the force specified and keeping the unit fixed for 10±1 sec. <table style="margin-left: auto; margin-right: auto;"> <tr> <td style="text-align: center;">Terminal diameter (mm)</td> <td style="text-align: center;">Force (Kg)</td> </tr> <tr> <td style="text-align: center;">0.5<d≤0.8</td> <td style="text-align: center;">1.0</td> </tr> <tr> <td style="text-align: center;">0.8<d≤1.25</td> <td style="text-align: center;">2.0</td> </tr> </table>	Terminal diameter (mm)	Force (Kg)	0.5<d≤0.8	1.0	0.8<d≤1.25	2.0	$ \Delta R_{25}/R_{25} \leq 10\%$									
Terminal diameter (mm)	Force (Kg)																	
0.5<d≤0.8	1.0																	
0.8<d≤1.25	2.0																	
Solderability	IEC60068-2-20	245 ± 3 °C , 3 ± 0.3 sec	At least 95% of terminal electrode is covered by new solder															
Resistance to Soldering Heat	IEC60068-2-20	260 ± 3 °C , 10 ± 1 sec	No visible damage $ \Delta R_{25}/R_{25} \leq 10\%$															
High Temperature Storage	IEC60068-2-2	T _u ± 5 °C , 1000 ± 24 hrs	No visible damage $ \Delta R_{25}/R_{25} \leq 20\%$															
Damp Heat, Steady State	IEC 60068-2-78	40 ± 2°C , 90 ~ 95 % RH , 1000 ± 24 hrs	No visible damage $ \Delta R_{25}/R_{25} \leq 20\%$															
Rapid Change of Temperature	IEC60068-2-14	The conditions shown below shall be repeated 5 cycles <table border="1" style="margin-left: auto; margin-right: auto;"> <thead> <tr> <th>Step</th> <th>Temperature (°C)</th> <th>Period (minutes)</th> </tr> </thead> <tbody> <tr> <td style="text-align: center;">1</td> <td style="text-align: center;">T_L ± 5</td> <td style="text-align: center;">30 ± 3</td> </tr> <tr> <td style="text-align: center;">2</td> <td style="text-align: center;">Room temperature</td> <td style="text-align: center;">5 ± 3</td> </tr> <tr> <td style="text-align: center;">3</td> <td style="text-align: center;">T_u ± 5</td> <td style="text-align: center;">30 ± 3</td> </tr> <tr> <td style="text-align: center;">4</td> <td style="text-align: center;">Room temperature</td> <td style="text-align: center;">5 ± 3</td> </tr> </tbody> </table>	Step	Temperature (°C)	Period (minutes)	1	T _L ± 5	30 ± 3	2	Room temperature	5 ± 3	3	T _u ± 5	30 ± 3	4	Room temperature	5 ± 3	No visible damage $ \Delta R_{25}/R_{25} \leq 20\%$
Step	Temperature (°C)	Period (minutes)																
1	T _L ± 5	30 ± 3																
2	Room temperature	5 ± 3																
3	T _u ± 5	30 ± 3																
4	Room temperature	5 ± 3																
Max. Current	IEC60539-1 4.26.1	25 ± 5 °C , I _{max.} , 1000 ± 24 hrs	No visible damage $ \Delta R_{25}/R_{25} \leq 20\%$															
Endurance	Specification Standard	25±5°C, I _{max.} , C _T , 1min ON / 5 min OFF x1000 cycles C _T =Capacitance at 240Vac	No visible damage $ \Delta R_{25}/R_{25} \leq 20\%$															
Insulation	MIL-STD-202F-Method 302	1000 V _{DC} 1 min	No visible damage ≥ 500 MΩ															

Products have been tested at Thinking Electronic Industrial Co., Ltd. Laboratory recognized by UL (Underwriters Laboratories Inc.) under CTD (Client Test Data Program).

Soldering Recommendation

■ Wave Soldering Profile

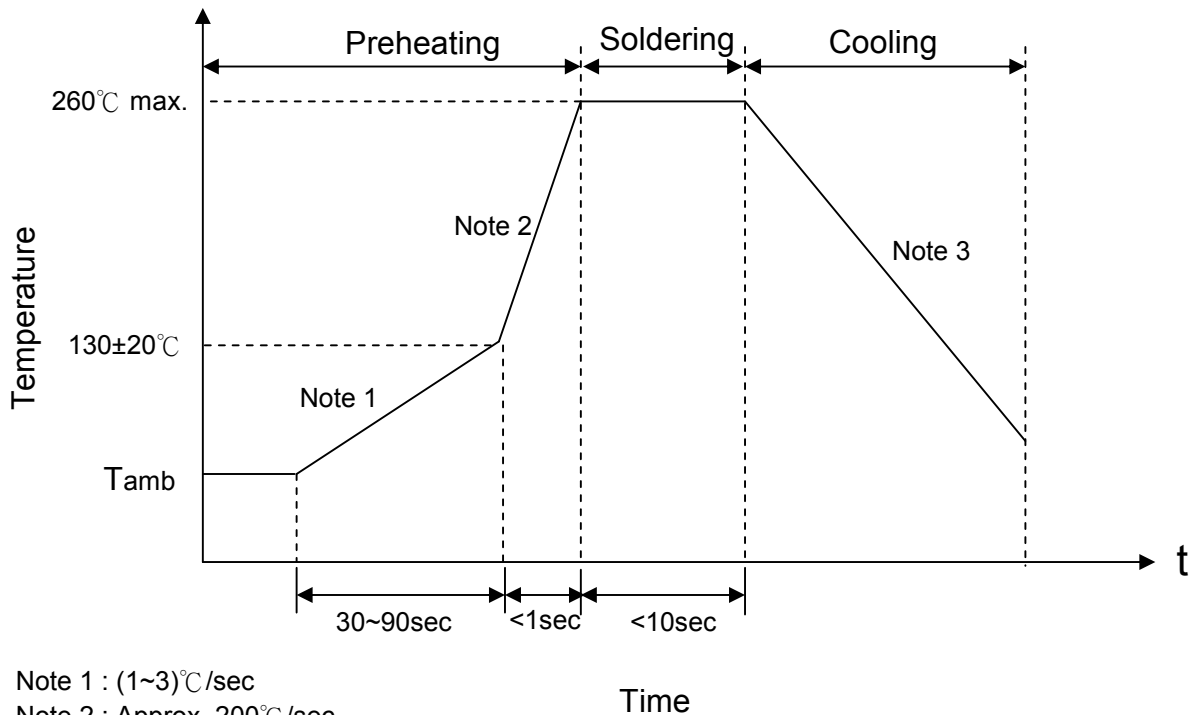

Note 1 : $(1 \sim 3)^\circ\text{C}/\text{sec}$

Note 2 : $\text{Approx. } 200^\circ\text{C}/\text{sec}$

Note 3 : $5^\circ\text{C}/\text{sec max}$

■ Recommended Reworking Conditions with Soldering Iron

Item	Conditions
Temperature of Soldering Iron-tip	360°C (max.)
Soldering Time	3 sec (max.)
Distance From Thermistor	2 mm (min.)

Max. Current Derating Curve

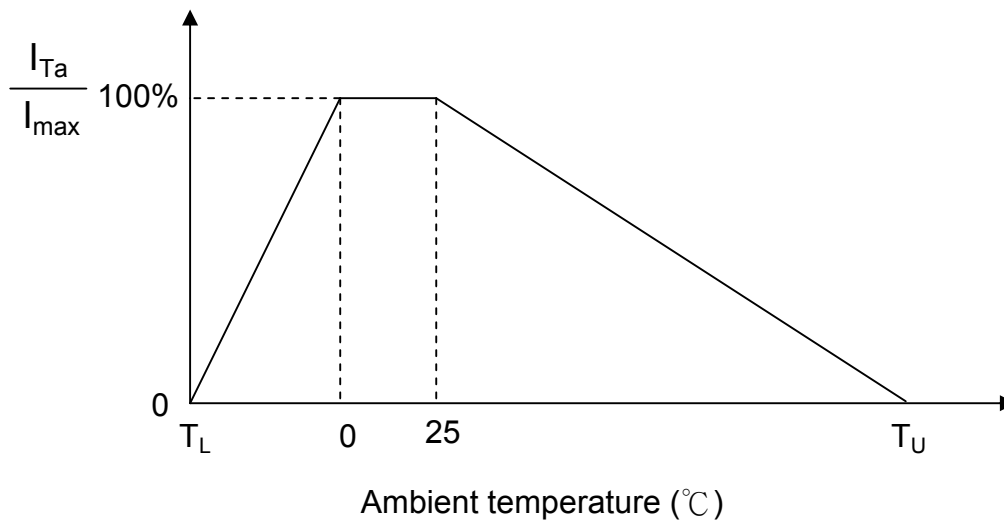

Note: T_L = Minimum operating temperature ($^{\circ}C$)

T_U = Maximum operating temperature ($^{\circ}C$)

For example :

Ambient temperature(T_a)=60 $^{\circ}C$

Maximum operating temperature(T_u)=200 $^{\circ}C$

$I_{Ta}=[1-(T_a-25)/(T_u-25)] \times I_{max}=80\%I_{max}$.

RoHS Compliant Declaration

We hereby declare that the components delivered to your company are compliant with RoHS directive 2011/65/EU.

Warehouse Storage Conditions of Products

(I) Storage Conditions :

- 1.Storage Temperature : -10 $^{\circ}C$ ~+40 $^{\circ}C$
- 2.Relative Humidity : $\leq 75\%RH$
- 3.Keep away from corrosive atmosphere and sunlight.

(II) Period of Storage : 1 year

Taping and Dimensions

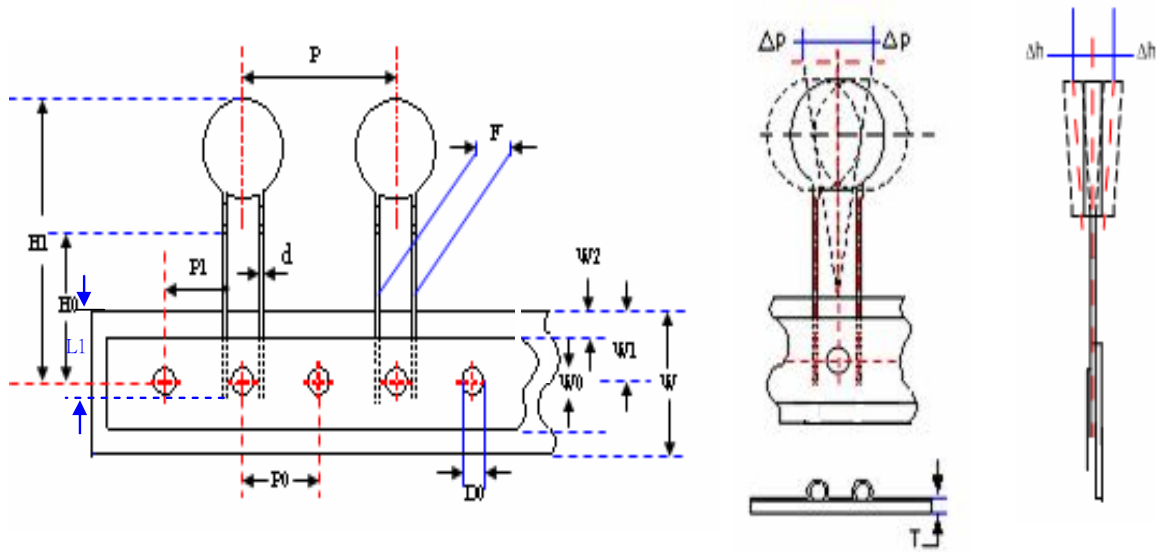

(Unit:mm)

Item	P0	F	P	P1	H0	H1	d	W0	W1	W2	W	△P	△h	L1	D0	T
	±0.3	±0.5	±1	±0.7	±0.5	Max.	±0.02	±1	+0.75 /-0.5	Max.	+1/-0.5	Max.	Max.	Min.	/	±0.2
	12.7	7.5	25.4	8.95	18	37	0.8	12	9	3	18	1	2	9	4-4.3	0.6

Standard Packing

(1) SPQ: 500pcs /reel

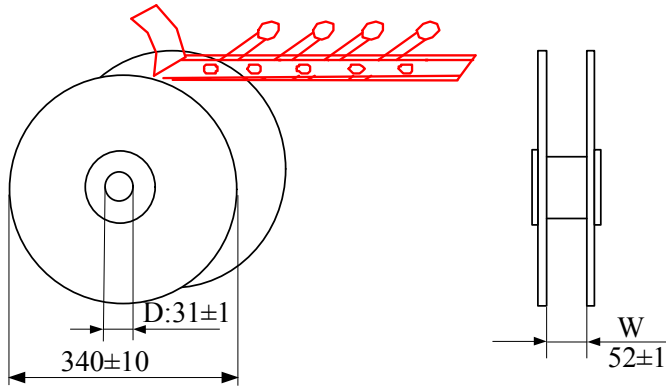

(Unit:mm)

(2) Inner box: 1 reel / box

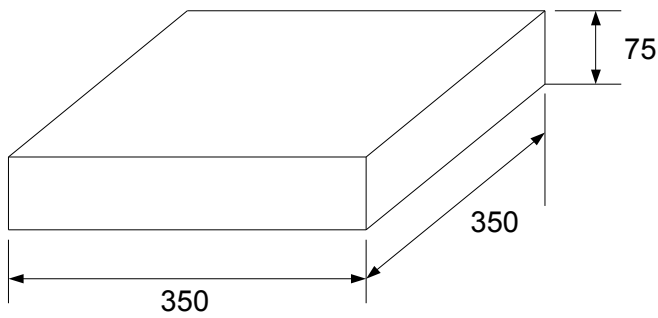

(Unit:mm)

(3) Carton: 4 Innerboxes / Carton

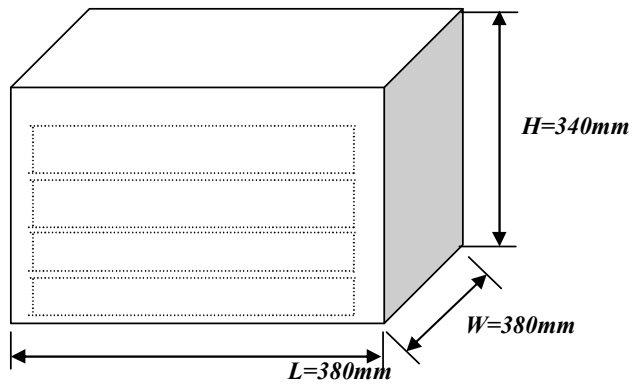

(Unit:mm)

Safety Approvals (Certified Model/Type : SCK-802X)

* UL 1434 / cUL recognized (File # E138827)



* CSA recognized (File # 97495)



* TÜV recognized (File # R 50050155)



* CQC GB/T 6663.1-2007 recognized (File # CQC05001011985)

* CQC GB/T 6663.1-2007 recognized (File # CQC05001011990)

Certificates

- (1) TS 16949 certificate
- (2) ISO 9001 certificate

Test Report

- (1) RoHS test report
- (2) Halogen-free test report



R-T Characteristic Curve

SCK15802XLFY501

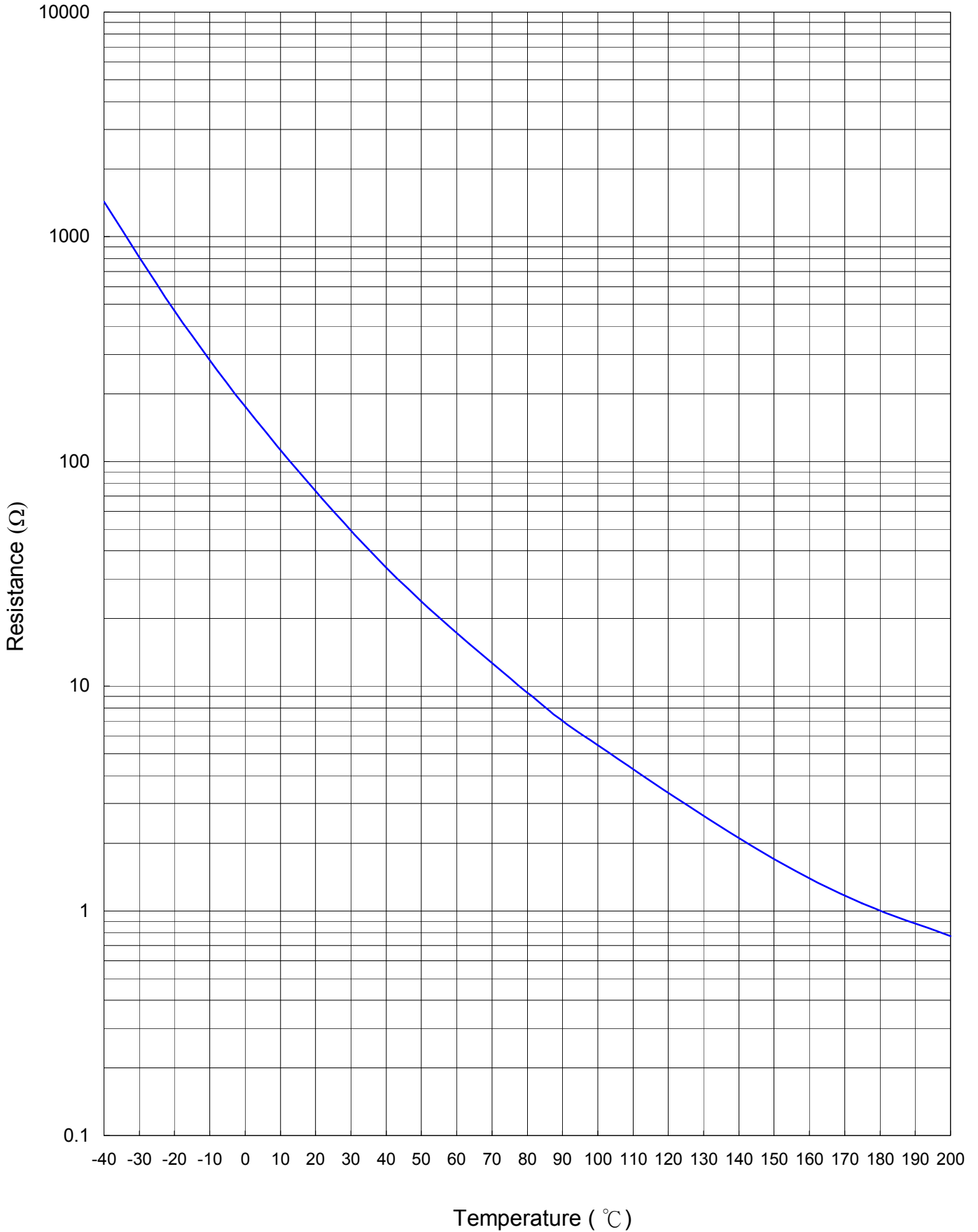

V-I Characteristic Curve (Ambient $T_a=25\text{ }^\circ\text{C}$)

SCK15802XLFY501

